

Batelaan Plastics Draws on SpaceClaim's Flexibility and Ease of Use to Create Unique Products for Global Companies

Thermoforming is a process whereby manufacturers can create finished products by using a vacuum to draw sheet plastic into a mold. Products range from retail displays for athletic sportswear companies to technical parts for automotive companies to liners for consumer goods, such as refrigerators. The process requires extensive experience and domain expertise. Batelaan Plastics, located in the Netherlands, works with global partners to customize products for their individual needs. The company is a family-owned business with more than 45 years in thermoforming and thermoforming machine development.

Ed Swets is the General Manager of Batelaan Plastics and oversees all design and technical execution.

ABOUT BATELAAN PLASTICS

Batelaan Plastics is headquartered in the Netherlands and serves customers worldwide. With an expertise in thermoforming, the company works with customers and partners to customize products that range from parts for electric cars, to chair lifts, display materials and agricultural equipment. The 45-year old, family-owned business leverages the latest technologies and tools to design and produce complex molds.



THE CHALLENGE: ADJUSTING DRAFT ANGLES AND THICKNESSES FOR MOLD CREATION

Batelaan creates a broad range of plastic products, including machine shells, parts for electric cars, chair lifts, fertilizers, display materials and other components. Designing molds for plastic parts is a very intricate operation. The mold has to be created so that the part can be ejected properly, requiring that the opening of the cavity be wider than the base. To accomplish this necessitates

tapering or creating "draft angles" to provide a clearance between the mold and the part. Complicating the challenge further is the fact that thermoplastics shrink as they cool.

Ed is constantly making new product and mold designs for parts and editing existing ones. Prior to using SpaceClaim®, his most effective process was to draw by hand or with Rhinoceros®. He needed software with the ability to read customers' 2D and 3D CAD data and adjust the design to those that could be manufactured. The manual process was tedious and required many calls with customers. If a change was made to a design, he had to make the adjustments by hand.

STREAMLINING THE WORKFLOW PROCESS AND REDUCING TIME-TO- MANUFACTURE BY 60 PERCENT

Customers either send Batelaan Plastics existing CAD files with fully developed products, or they have

ideas only with no documentation and Ed has to create 3D proposals. Once the proposal is approved, Batelaan Plastics proceeds to a prototype and then to production.

When Ed tried SpaceClaim to alleviate his time-consuming process of part design and mold creation, he was "relieved." He leverages the flexibility of SpaceClaim to easily create draft angles, adjust for shrinkage, and ready the part and mold for manufacturing – without any constraints.

"Manually recreating designs in our CAD system was a cumbersome process: it did not showcase our work well for prospects, and it took a lot of time. Now with SpaceClaim I have no limitations for design, our communications with customers are improved, and we've saved 60% to 70% of our time, enabling us to take on more business," Ed Swets.

When designing for the thermoform process, Ed is able to use SpaceClaim to view the plastic in cross sections to better

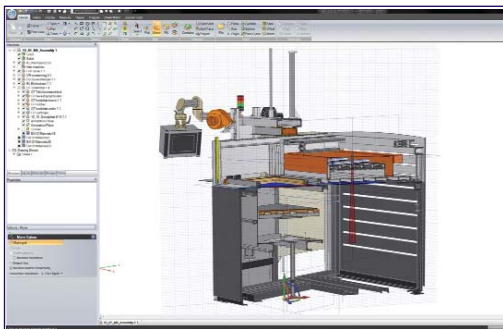

Figure 1: Thermoform machine unit M6 free and perfectly filled.

Satellite Payload Launched with SpaceClaim at The Florida Institute of Technology

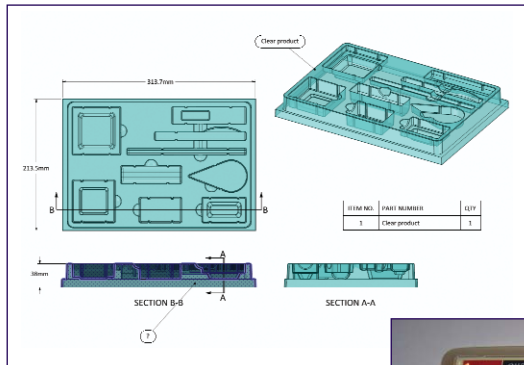

Figure 2: Inlay promobox office equipment
Material: APET 0,6 mm transparent

Figure 3: Mould Inlay promobox office equipment



understand issues in manufacturing. Batelaan provides customers with support from design through manufacturing, and SpaceClaim has quickly become a vital tool to design new products, tweak customer models, and create molds from them. By direct modeling in a combination of SpaceClaim's cross section and 3D editing capabilities, Ed is able to easily adjust the customers' designs so the round radii, draft angles, and scale are correct. For plastic that becomes stretched, Ed can adjust the material thickness base on his proprietary rules, helping guarantee the accuracy of parts the first time. Once the parts are correctly designed, Ed prepares the mold using SpaceClaim's Volume Extract tool on the core of the part, adding vacuum holes in strategic locations.

Ed uses McNeel's Rhino for final rendering and the seamless integration between SpaceClaim and Rhino has enabled him to exchange files easily. If documentation is required, Ed uses SpaceClaim for line

drawings and extrusion drawings. To machine the molds, Ed turns to MecSoft's VisualMill, which is also integrated with SpaceClaim.

Recently, Batelaan has started using SpaceClaim to design custom-built thermoforming machines that further lower their manufacturing and labor costs. These machines can contain thousands of parts and require dozens of assembly drawings.

"Customers rely on our expertise and the quality of our finished products. SpaceClaim has made a big difference throughout the product development and design phase and has eliminated many of the issues we were facing in readying products for manufacture," Ed Swets.

Not only does SpaceClaim help Batelaan provide better customer service, higher quality parts, quicker turnaround, and lower prices, it also helps them out-innovate their competitors.

"Customers rely on our expertise and the quality of our finished products. SpaceClaim has made a big difference throughout the product development and design phase and has eliminated many of the issues we were facing in readying products for manufacture."

Ed Swets
General Manager
Batelaan Plastics



150 Baker Ave. Ext., Concord, MA 01742 USA
Tel: +1 978.482.2100 Fax: +1 978.369.5864